



GAO Research Inc. ADSL (G.992.1) Softmodem

GAO Research Inc.

#1 In Embedded Communications Software

Features

► High Speed

- Data rates of up to 1.5 Mbps downstream and 512 Kbps upstream
- About 55 times faster than V.34 modems
- About 30 times faster than V.90 modems
- About 12 times faster than ISDN modems

► Always on-line and connected

- The modem is always connected so no time is wasted dialing up the service several times a day and waiting to be connected.

► Continuous access telephone service

- The telephone can be used for normal conversation or faxes can be sent/received while the Internet connection is up.

► Can be integrated with GAO's V.92, V.90, or softmodems

Product Description

GAO's ADSL softmodem offers extremely high bit rates of up to 8 Mbps downstream and 640 Kbps upstream and provides a POTS channel for either a telephone or a V-series modem.

Tests at many telephone companies have proven that ADSL technology is practical and many North American telephone companies have already rolled out commercial services. As consumers continue to demand higher capacity access technologies for Internet applications and ADSL technology matures and becomes more ubiquitous, the ADSL modem will become the driving force of the modem market. r section.

GAO's ADSL softmodem uses the Discrete Multi-Tone (DMT) modulation technique. The DMT line code sends multiple tones of data over the line allocating more data to the lower frequencies where there are less analog impairments.

ADSL modems also split incoming data into two streams - a fast stream and an interleaved stream. Interleaving a portion of the data facilitates error correction by giving protection against noise bursts at the cost of higher latency. This means that some of the components are doubled, one for the fast stream and one for the interleaved stream.

Integration of GAO's ADSL and V.90 softmodems is made possible by the POTS channel that ADSL technology provides. This integration technique can be applied to both splitter based ADSL and splitterless ADSL - G.Lite. As illustrated in Figure 1, ADSL channel splitting gives wide bandwidth for Internet applications and doesn't affect regular telephone service. The V.90 softmodem function offers bit rates of up to 56 kbps downstream and 33.6 kbps upstream. It makes use of the POTS channel and serves as a fallback if the ADSL service fails or is not available. Telephone service may also be accessed through the POTS channel if the V.90 modem is not used.

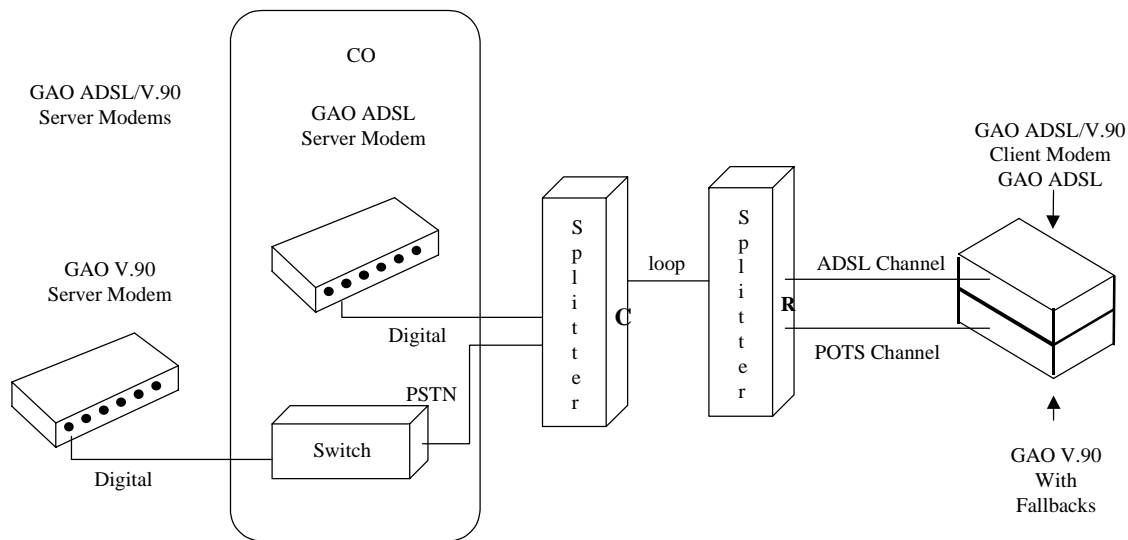

Figure 1 – Integration of GAO’s ADSL & V.90 Softmodem

Leadership in Embedded Communications Software

With nearly two decades of experience, GAO leads the embedded communications software market by providing comprehensive modem, fax, speech, and telephony technologies; broad technical expertise; and unsurpassed support to our world-class customers including electronics, communications, and semiconductor companies across the globe. GAO’s software integrates easily with MP3, MPEG, TCP/IP, and most popular real-time operating systems.

Rigorous Testing

GAO’s testing facilities are equipped with state-of-the-art test equipment. Our modem and fax software is rigorously tested on TAS, Consultronics, Rochelle, Advent and Telegra equipment under various channel models according to the relevant ITU or TIA standards. All GAO’s speech software has passed the test vectors specified by the ITU. Our telephony software meets all appropriate TIA, EIA, BellCore, and Mitel standards. GAO also adheres to stringent quality control procedures, which is reflected in our well structured code, detailed design documentation, and well-defined design and test plans. This ensures ease of integration into the customer’s system, easy maintenance, and a smooth upgrade path for next-generation customer products.

Contact Information

GAO Research Inc.

10 Milner Business Court, Suite 701
 Toronto, Ontario M1B 3C6 Canada

Tel: 1-(416) 292-0038

Fax: 1-(416) 292-2364

E-mail: info@gaoresearch.com

Web: www.gaoresearch.com